

VA-715x Electric Valve Actuator

The VA-715x Series synchronous motor-driven actuator provides incremental (three wire), incremental with feedback, or proportional control of valves with up to 3/4 in. stroke in heating, ventilating, and air conditioning applications.

This compact, non-spring return actuator has a 90 lb force minimum and responds to a variety of input signals.

The VA-715x Series can be easily field mounted or ordered factory coupled to VT Series terminal unit valves, VG7000 Series valves, or VBC Series bronze cage trim valves. In addition, this actuator can be field mounted to 1/2 in. flare valves. Refer to the VT, VBC, VG7000, and VTF Series bulletins for available configurations.



Figure 1: VA-715x Electric Valve Actuator

Features and Benefits		
q	90 lb Force Output in a Compact Unit	Covers a wide range of applications with one actuator
q	Magnetic Clutch	Provides constant output force for positive closeoff of valves, and protects motor in stall conditions
q	Durable Construction	Provides a longer cycle life
q	Unique Yoke Design	Easy field mounting to valves reduces installation and stroke adjustment time
q	Selectable Direct/Reverse Action	Eases setup and installation

Operation

The VA-715x Series actuators use a reversible synchronous motor and a magnetic clutch to accurately position the valve. This combination can reliably generate 90 lb of force in either direction.

The actuator maintains the shutoff force even if power to the actuator is removed. When the controller provides a signal for the actuator to move in the opposite direction, the shutoff force is reduced and the valve modulates.

The magnetic clutch maintains a constant load at the end of travel, which ensures tight valve shutoff and compensates for seat wear.

Incremental Control--VA-7150

A controller provides 24 VAC to the Up, Down, and Common terminals depending upon the desired movement of the valve stem. This signal causes the motor to rotate in the proper direction. The gear train and drive screw move the valve stem up or down. When the controller stops sending a signal, the valve stem is held in place and remains in position until the next control signal is sent.

Note: In incremental applications, there is no direct correlation between valve position and controller output (0 to 100%). If correlation is important, use proportional control or actuators that provide position feedback.

Feedback Control--VA-7153

VA-7153 actuator operation is the same as the VA-7150, while providing position feedback.

A 2k ohm position feedback potentiometer provides remote position indication to the control system. The 0 to 2k ohm feedback potentiometer is proportional to the full 3/4 in. actuator stroke and includes a field adjustable zero.

Proportional Control--VA-7152

The VA-7152 provides a proportional stroke in relation to the input control signal of 0 to 10, 0 to 5, or 5 to 10 VDC jumper selectable input control signal. It also features stroke selection and Direct Acting (DA) or Reverse Acting (RA) jumpers.

An electronic controller provides the proportional input signal to the VA-7152. This signal is compared to the actual valve position via the internal feedback potentiometer.

The internal circuit activates the motor to rotate in the proper direction. The gear train and drive screw move the valve stem to the position called for by the input signal.

Note: The actuator will accept control signals of 20 VDC maximum with signals over 10 VDC ignored by the actuator.

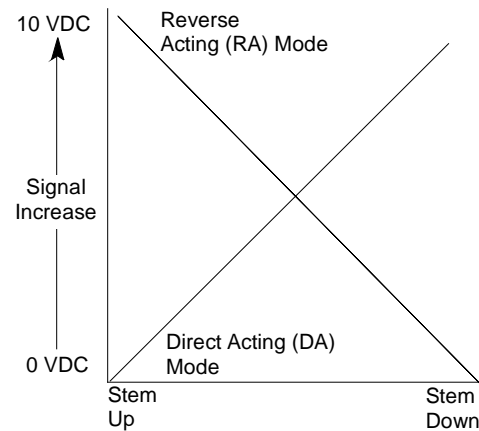

Figure 2: Direct/Reverse Action

Dimensions

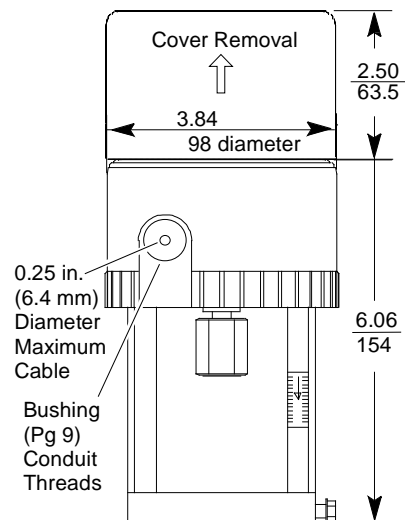

Figure 3: VA-715x Series Dimensions (in./mm)

Installation

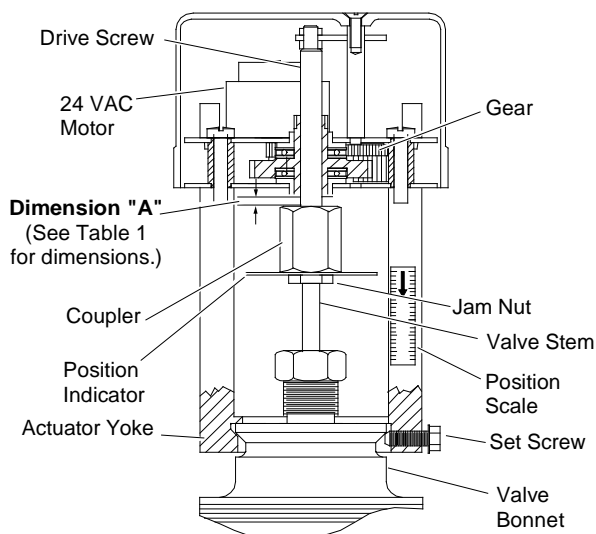

Figure 4: Actuator Components as Mounted on VBC Series Cage Trim Valve

Kit Includes

- VA-715x Actuator
- jam nut
- position indicator
- two position scales

Note: No additional parts are required for mounting to VBC Series valves. (See Figure 4.)

Tools Required

- wrenches, 3/4 (19 mm) and 9/16 in. (14 mm) open end or adjustable
- nut driver, 5/16 in. (8 mm)
- screwdrivers, 3/32 in. and 3/16 in. flat-blade

Procedures

1. Verify the valve stroke by measuring the valve stem in the full down and full up positions. The difference is the valve stroke.

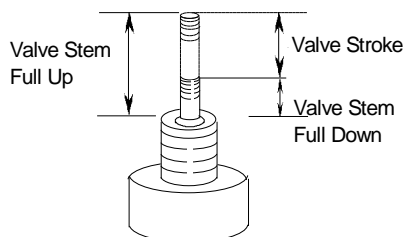

Figure 5: Measuring Valve Stroke

2. Unpack the actuator and remove its cover by removing the single screw in the top.
3. Manually turn the gearing between the metal plates to achieve **Dimension "A"** as shown in Figure 4. (Use Table 1 to set Dimension A.)

Table 1: Dimension "A" Gap Reference

Valve Family	Valve Size or Style	Valve Stroke	Dimension "A"
VT Series Valves	1/2 in.	5/16 in. (8 mm)	5/32 in. (4 mm)
VBC Series Cage Trim Valves	3/4 in.	1/2 in. (13 mm)	5/64 in. (2 mm)
	1, 1-1/4, 1-1/2, and 2 in.	3/4 in. (19 mm)	5/64 in. (2 mm)
	1/2 and 3/4 in.	5/16 in. (8 mm)	5/64 in. (2 mm)
VG7000 Series Valves	1 and 1-1/4 in.	1/2 in. (13 mm)	5/64 in. (2 mm)
	1-1/2 and 2 in.	3/4 in. (19 mm)	5/64 in. (2 mm)
	VB-4332 (3-Way Mixing)	5/16 in. (8 mm)	5/32 in. (4 mm)
Flare Valves (1/2 in. only)	VB-3766 (N.O.) and VB-3966 (N.C.)	1/2 in. (13 mm)	5/64 in. (2 mm)
	Honeywell* V50xxx	1/2 - 3 in.	3/4 in. (19 mm)
Siebe* (Barber-Colman) VB-9xxx	1/2 to 1-1/4 in.	3/8 in. (9.5 mm)	5/64 in. (2 mm)
		1/2 in. (13 mm)	5/64 in. (2 mm)

* Requires a mounting kit from the *Accessories* table.

Note: It is necessary to manually turn the gearing several times before you see movement of the drive screw and the coupler.

4. Thread the jam nut onto the valve stem down to the end of the thread.
5. Place the position indicator on top of the jam nut as shown in Figure 6.

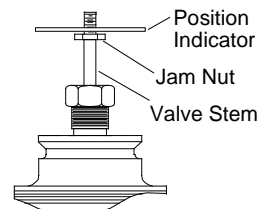

Figure 6: Installing Nut and Position Indicator

6. Push valve stem in so it is in full down position.
7. Position the actuator on the valve bonnet, and use a 5/16 in. nut driver to tighten the set screw.

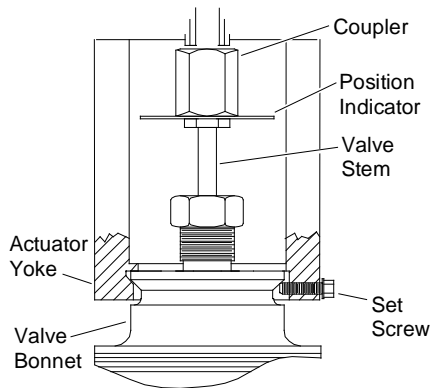

Figure 7: Installing the Actuator

8. Lift the stem to meet the coupler and then screw the coupler onto the stem until the valve reaches the end of stroke in the full up position. (Coupler should be turned a minimum of four revolutions.)
9. While holding the coupler in place, hand tighten the jam nut against the coupler. Using 3/4 and 9/16 in. open end wrenches, tighten the coupler and jam nut an additional 1/8 to 1/4 turn.
10. Insert the wires through the bushing in the actuator housing.

Note: The VA-7150-1900 Conduit Adaptor Kit is available if connection to 1/2 in. conduit is needed.

11. Connect the wires to the actuator using the appropriate wiring diagrams, see the *Wiring* section.
12. Provide the control signal to drive the actuator up and down at least two complete cycles to check actuator for proper operation.
13. Verify that the actuator is fully seating the valve in the full down position and that the initial clearance (Step 3) is maintained in the full up position.

Note: If the valve is not fully seating in the down position, decrease gap Dimension “A” by reducing the thread coupler engagement. The gap must be sufficient to allow actuator to stall at the end of stroke.

14. Attach the position scale label to the actuator yoke as shown in Figure 8. Place the second label on the backside of yoke.

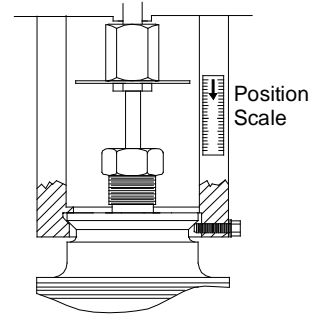

Figure 8: Installing the Position Scale

15. Proceed with adjustments in the *Adjustments* section if required. Otherwise, replace the cover and tighten the cover screw.

Note: If adjustments are required, refer to the following:

- VA-7152: *Adjustments* section
- VA-7153: *Adjustments* section

Wiring

WARNING: **Equipment Damage Hazard.** Disconnect the power supply before wiring connections are made to prevent possible damage to the equipment. Make and check all wiring connections before applying power to the system. Short-circuited or improperly connected wires may result in permanent damage to the unit.

All wiring must be in accordance with applicable electrical code requirements. Input lines to the actuator must be wired correctly for the valve to move in the proper direction.

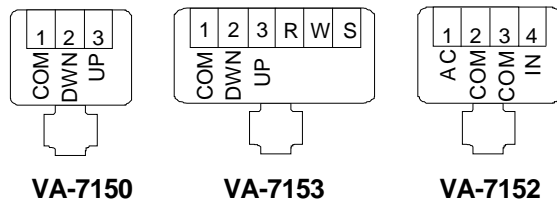

Figure 9: Application and Drawing Identification

Note: Follow wiring and termination instructions detailed in the applicable controller manual.

Incremental Control--VA-7150

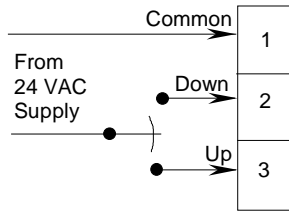

Figure 10: Basic Incremental Wiring

Table 2: VA-7150 Action

Energizing Terminals	Actuator Drive Screw
1-2	Extends
1-3	Retracts

Incremental control wiring should be connected to terminals: (1) Common, (2) Down, and (3) Up. (Terminal 17 is not used.) Providing power to Terminals 1 and 2 will cause the actuator drive screw to extend, pushing the valve stem down. Providing power to Terminals 1 and 3 will cause the actuator drive screw to retract, pulling the valve stem up.

Incremental Control with Feedback--VA-7153

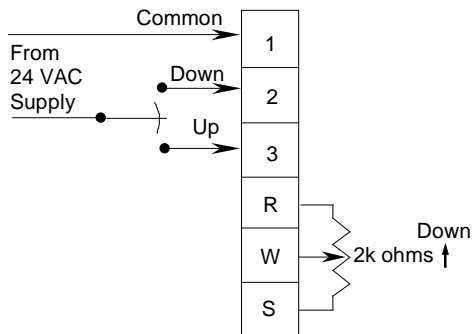

Figure 11: Basic Feedback Wiring

Table 3: VA-7153 Resistance Change

Actuator Drive Screw	Feedback Resistance Change	
	R - W	W - S
Extends	Decrease	Increase
Retracts	Increase	Decrease

Incremental control wiring should be connected to terminals: (1) Common, (2) Down, and (3) Up. Providing power to Terminals 1 and 2 will cause the actuator drive screw to extend, pushing the valve stem down. Providing power to Terminals 1 and 3 will cause the actuator drive screw to retract, pulling the valve stem up.

The position feedback potentiometer is connected to Terminals R, W, and S. Terminals R and S are a fixed 2000 ohm resistance. The potentiometer wiper is connected to Terminal W. Resistance change vs. actuator travel is shown in Figure 12.

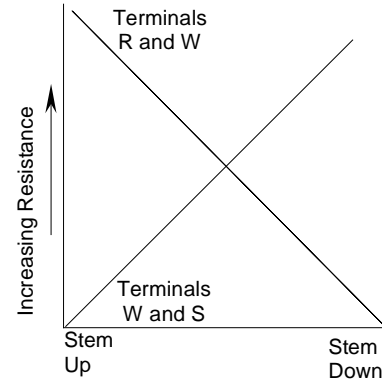

Figure 12: Feedback Resistance

Proportional Control--VA-7152

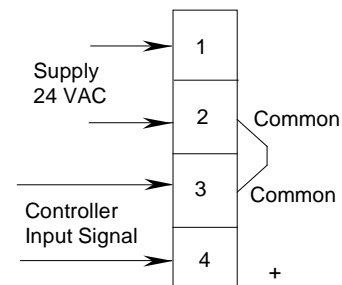

Figure 13: Basic Proportional Wiring

Note: Terminals 2 and 3 are tied together on the circuit board.

Table 4: VA-7152 Action

Input Signal	Actuator Drive Screw	
	DA	RA
Increase	Extends	Retracts
Decrease	Retracts	Extends

Voltage supply wiring should be connected to terminals: (1) AC and (2) Common. Control wiring is to terminals (3) Common (-) and (4) IN (+).

With a low control signal voltage applied across Terminals 3 and 4, the actuator drive screw will be fully retracted in Direct Acting (DA) mode, and fully extended in Reverse Acting (RA) mode. With a high control signal voltage applied across Terminals 3 and 4, the actuator drive screw will be fully extended in Direct Acting (DA) mode, and fully retracted in Reverse Acting (RA) mode.

In Direct Acting (DA) mode, an increasing signal will cause the actuator drive screw to extend, pushing the valve stem down. A decreasing signal will cause the actuator drive screw to retract, pulling the valve stem up. In Reverse Acting (RA) mode, a decreasing signal will cause the actuator drive screw to extend, pushing the valve stem down. An increasing signal will cause the actuator drive screw to retract, pulling the valve stem up (see Figure 2).

Adjustments

Feedback Control--VA-7153

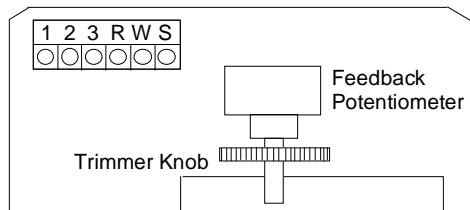

Figure 14: VA-7153 Feedback

Adjusting Feedback Resistance

With the actuator retracted (valve stem fully up), the actuator is factory calibrated for 0 to 100 ohms maximum across Terminals W and S.

Note: Feedback requirements may vary depending upon application and controller calibration.

For example, to calibrate the actuator for 1000 ohms at mid stroke (50% of travel):

1. Drive the valve so the actuator valve stem is in the full up position.
2. Use an ohmmeter to measure the resistance between Terminals W and S.
3. Adjust the trimmer knob until you read 20 to 40 ohms on the meter.
4. Drive the actuator so that the valve is in the full down position.
5. Measure the resistance between Terminals W and S with the ohmmeter.
6. Drive the actuator toward the center of its stroke and stop when the resistance is 50% of the value measured in Step 5.
7. Adjust the trimmer knob until you read 1000 ohms on the meter.

Note: The actuator is now calibrated for 1000 ohms at mid stroke (50% of travel).

8. Replace the cover and secure with the screw. The unit is ready for operation.

Proportional Control--VA-7152

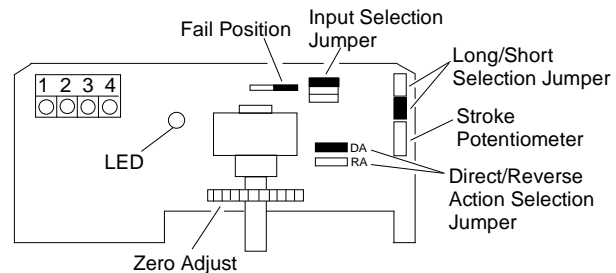

Figure 15: VA-7152 Components

Factory calibration is set for direct acting 1 to 9 VDC ± 0.5 VDC for use with 0 to 10 VDC controller and 5/16 in. stroke VT Series valve, Push Down to Close (PDTTC) applications. The signal fail position jumper is factory positioned for fully up.

Note: The actuator will accept control signals of 20 VDC maximum with signals over 10 VDC ignored by the actuator.

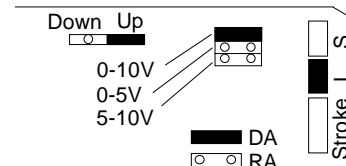

Figure 16: Jumpers

Calibration

1. Set the input selection jumpers to match the desired operating range. (See Figure 16.)
 - Top Jumper = 0 to 10V
 - Center Jumper = 0 to 5V
 - Bottom Jumper = 5 to 10V
2. Set the short/long travel selection jumper:
 - short for stroke lengths 1/2 in. or less
 - long for strokes over 1/2 in.
3. Set the direct/reverse action jumper so that the valve stem travels in the desired direction (per changes in control signal).
 - DA (Top Jumper) = stroke down on signal increase
 - RA (Bottom Jumper) = stroke up on signal increase

- Set the signal fail position jumper to select default position of fully up or fully down. If the signal is lost at the actuator (open connection), the actuator will default to the pre-designated position of full up or full down.
- Apply voltage specified by application requirements to drive the actuator to the full up position using the following chart:

Table 5: VA-7152 Calibration Values

Application Values	Calibration Values
0-10	1-9
0-5	1-4
5-10	6-9

Note: Use of the calibration values in Table 5 will ensure proper shutoff throughout the life of the valve (accounts for seat wear).

- DA: full up (minimum voltage)
- RA: full up (maximum voltage)

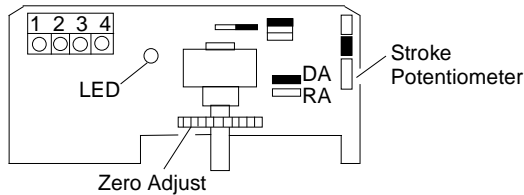

Figure 17: VA-7152 Adjustments

- To ensure that the valve stem is in the full up position, turn the zero adjust knob (shown in Figure 17) completely to the left, until the valve stem reaches the end of stroke.
- Slowly turn the zero adjust knob to the right, and stop as soon as the LED flashes or goes out.

Note: As the actuator is driving, the LED will be on. The actuator circuit contains a time out feature. If calibration takes longer than 3-10 minutes, the LED will go out giving a false satisfied condition. If this occurs, turn off the power, wait several seconds, turn the power to the actuator back on, and then readjust the zeroing knob.

- Apply the input voltage specified by application requirements to drive the valve stem to the full down position per Table 5.
- To ensure that the valve stem is in the full down position, adjust the stroke potentiometer fully Clockwise (CW) until the valve stem reaches the end of stroke.

- Slowly turn stroke potentiometer Counterclockwise (CCW) until LED goes off.
- Adjust voltage to drive actuator to the full up position. Verify zero adjustment.
- Check for proper operation using the desired minimum and maximum operating voltages. Allow the actuator to operate through several complete cycles.

Note: The LED will remain on for 3-10 minutes after the actuator has completed operation cycle.

- Replace the cover and secure with the screw. The unit is ready for operation.

Ordering Information

To order a VA-715x Series Electric Actuator, specify the complete product code number:

Table 6: Products Available

Code Number	Description
VA-7150-1001	Three Wire Incremental
VA-7153-1001	Three Wire Incremental with Position Feedback
VA-7152-1001	Proportional, 0 to 10 VDC

Table 7: Accessories

Code Number	Description
V-9999-670	Bonnet Adapter used for field mounting to VT Series valve body with threaded stem
Y20EBE-2	Adapter Kit required to field mount VT Series valve body with slotted stem
VA-7150-1900	Conduit Adapter Kit used to adapt actuator Pg 9* threads to 1/2 in. conduit
V-9999-BC1	Bonnet Adapter used for field mounting to 1/2 to 1-1/4 in. VB-9xxx Series Siebe (Barber-Colman) valves
V-9999-HW1	Bonnet Adapter used for field mounting to V5011 A, F, G 1/2 to 3 in. single-seated and V5013F three way Honeywell® valves

* European measurement for conduit threads

Repair Information

Field repairs must not be made. For a replacement actuator, contact the nearest Johnson Controls representative.

Specifications

Product	VA-7150:	Three wire incremental
	VA-7153:	Three wire incremental with position feedback
	VA-7152:	Proportional, 0 to 10 VDC
Power Requirements	24 VAC (20 to 30 VAC), 50/60 Hz	
	VA-7150:	2.7 VA nominal
	VA-7153:	2.7 VA nominal
	VA-7152:	4.7 VA nominal
Input Signal	Incremental:	24 VAC, 50/60 Hz
	Proportional:	0 to 10 VDC
Input Signal Adjustments (Proportional)	Input Signal:	0 to 10, 0 to 5, 5 to 10 VDC (jumper selectable)
	Action:	Drive up (DA) or drive down (RA) on signal increase (jumper selectable)
	Factory Setting:	Calibrated 1 to 9 ± 0.5 VDC for 0 to 10 VDC controller operation, Direct Acting (DA), 5/16 in. (8 mm) stroke for VT series valve
Input Impedance (Proportional)	100k ohms	
Feedback Signal	VA-7153:	0 to 2000 ohms $\pm 20\%$ for 25/32 in. (20 mm) stroke, 1/4 watt
Mechanical Output	90 lb force (400N) minimum	
Stroke Range	25/32 in. (20 mm) maximum	
Nominal Stroke Timing	60 Hz:	70 seconds 5/16 in. (8 mm) stroke 110 seconds 1/2 in. (13 mm) stroke 165 seconds 3/4 in. (19 mm) stroke
	50 Hz:	85 seconds 5/16 in. (8 mm) stroke 135 seconds 1/2 in. (13 mm) stroke 200 seconds 3/4 in. (19 mm) stroke
Electrical Connections	Screw Terminals:	VA-7150: 24 to 14 AWG VA-7153: 24 to 16 AWG VA-7152: 24 to 16 AWG
Mechanical Connections	1/4-28 UNF-2B thread for valve stem connection	
Enclosure	NEMA 1, IP40	
Ambient Operating Conditions	0 to 140°F (-18 to 60°C), 10 to 90% RH, non-condensing, 86°F (30°C) maximum dew point	
Ambient Storage Conditions	-4 to 150°F (-20 to 65°C), 5 to 95% RH, non-condensing, 86°F (30°C) maximum dew point	
Dimensions	3.84 in. diameter x 6.06 in. high (98 x 154 mm)	

Shipping Weight	1.7 lb (0.77 kg)
Agency Compliance	United States: UL Listed, CCN XAPX, File E27734; to UL 60730-1A: 2003-08, Ed. 3.1, Automatic Electrical Controls for Household and Similar Use; and UL 60730-2-14: 2002-02, Ed. 1, Part 2 Particular Requirements for Electric Actuators
	Canada: UL Listed, CCN XAPX7, File E27734; to UL 60730-1:02-CAN/CSA: July 2002, 3rd Ed., Automatic Electrical Controls for Household and Similar Use; and CSA C22.2 No. 24-93 Temperature Indicating and Regulating Equipment
	Europe: CE Mark – Johnson Controls, Inc., declares that this product is in compliance with the essential requirements and other relevant provisions of the EMC Directive 2004/108/EC and Low Voltage Directive 2006/95/EC.
	Australia and New Zealand: C-Tick Mark, Australia/NZ Emissions Compliant



The performance specifications are nominal and conform to acceptable industry standards. For application at conditions beyond these specifications, consult the local Johnson Controls office. Johnson Controls, Inc. shall not be liable for damages resulting from misapplication or misuse of its products.



Building Efficiency
 507 E. Michigan Street, Milwaukee, WI 53202

Metasys® and Johnson Controls® are registered trademarks of Johnson Controls, Inc. All other marks herein are the marks of their respective owners. © 2013 Johnson Controls, Inc.